

Etanorm GPV-D/CPV-D Etanorm GPV-W/CPV-W

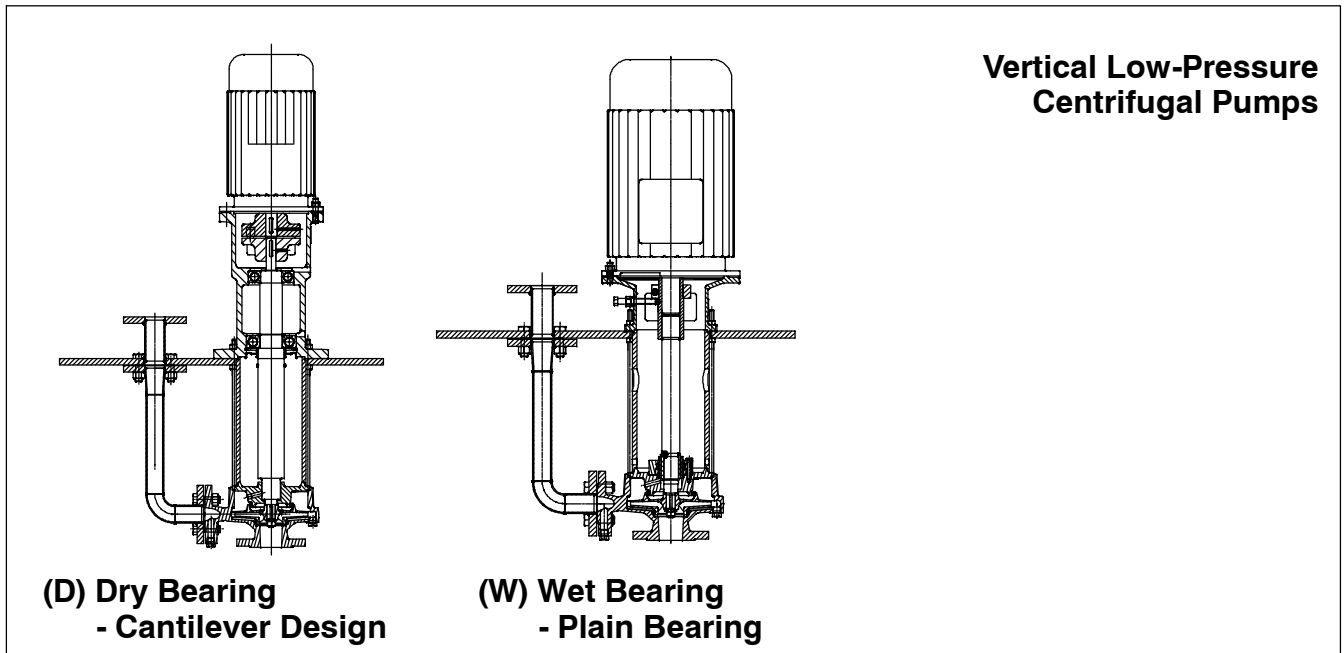

Fields of Application

Etanorm GPV/CPV pumps are used for handling neutral degreasing and phosphatizing solutions, washing water with degreasing agents, dipping paints, etc. *

* Phosphatizing solutions and electro-dip paints (e.g. cathoretic dip paint) are not permissible for design W

Operating Data

Q up to 660 m³/h (183 l/s)

H up to 100 m

p₂ 10 bar

t up to +70 °C (design D),
+95 °C (design W)

Design

Volute casing pumps, single-stage, with capacities to EN 733, for vertical installation in closed tanks under atmospheric pressure (wet installation).

Volute casing and impeller with replaceable wear rings.

Bearings

Design D

Deep-groove ball bearing greased for life in a bearing bracket lantern above the cover plate.

Pump shaft in cantilever design without bearing below the cover plate.

Design W

Rigid coupling between pump and motor shaft, SiC/SiC plain bearing product-lubricated at the impeller end.

Certification

Certified quality management ISO 9001.

Designation

Etanorm GPV-W 50-250

Type series _____
Casing material 1) _____
Vertical design _____
Shaft bearing 2) _____
Discharge nozzle DN _____
Nominal impeller dia. in mm _____

1) G = Grey cast iron JL1040 (GJL-250 as per EN 1561)

C = Chrome nickel molybdenum cast steel 1.4408

2) see Bearings

Accessories

Drive:

Surface-cooled KSB IEC three-phase squirrel cage motor

Winding: up to 2.2 kW 220-240 V/380-420 V
3 kW and above: 380-420/660-725 V

Design: up to 4 kW IM V1
5.5 kW and above: IM V 15

Enclosure: IP 55

Thermal class: F with temperature sensors: 3 PTC
thermistors

Operating mode: continuous operation S1

or

surface-cooled three-phase squirrel cage motor as described above, but West European brand to KSB's choice.

Contact Guard

Cover plates at the bearing lantern/motor stool ³⁾ to EN 294

³⁾ Design D with bearing lantern; design W with motor stool

Other

Well cover with riser.

Selection charts

n = 2900 rpm

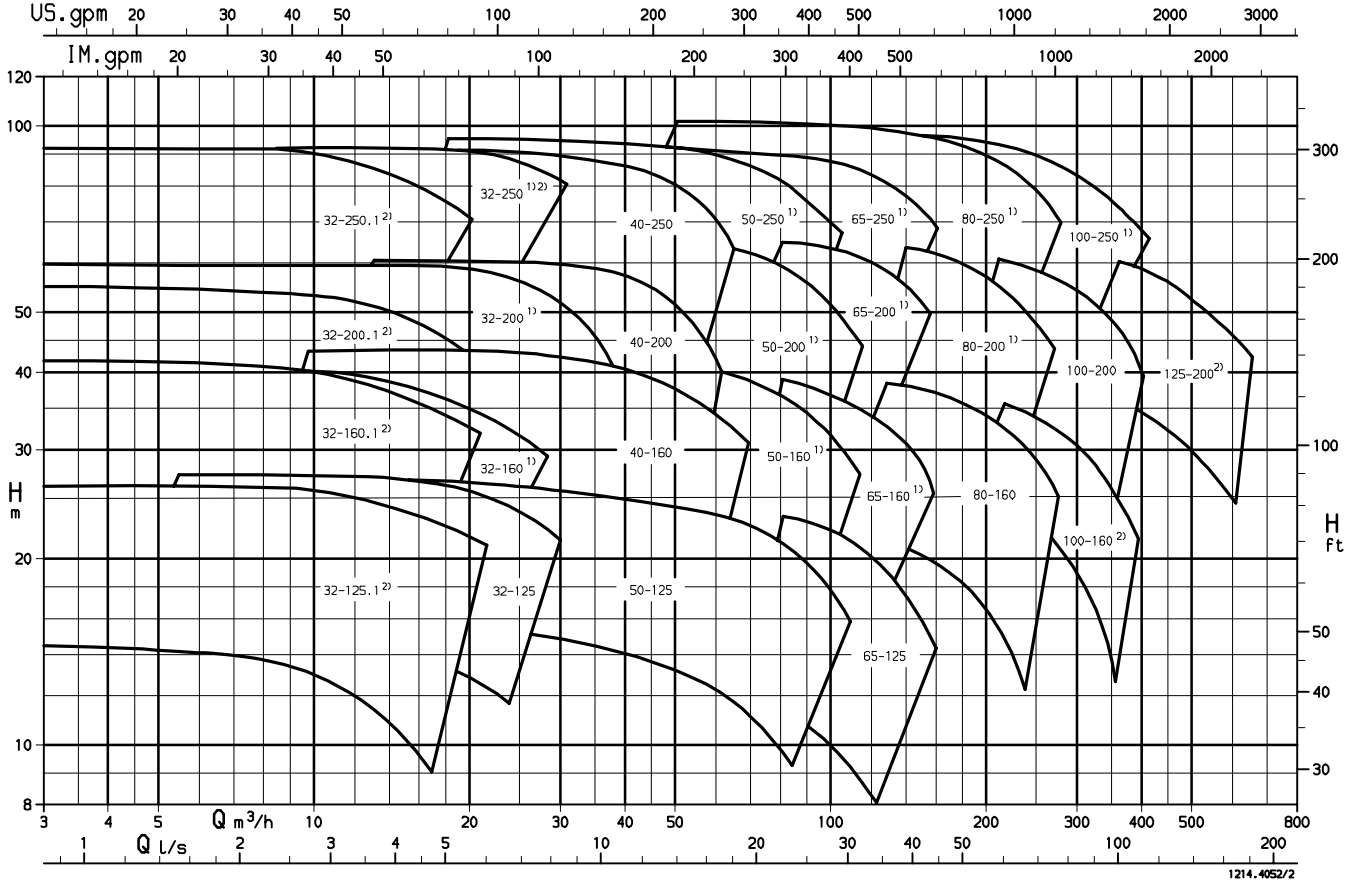

n = 1450 rpm

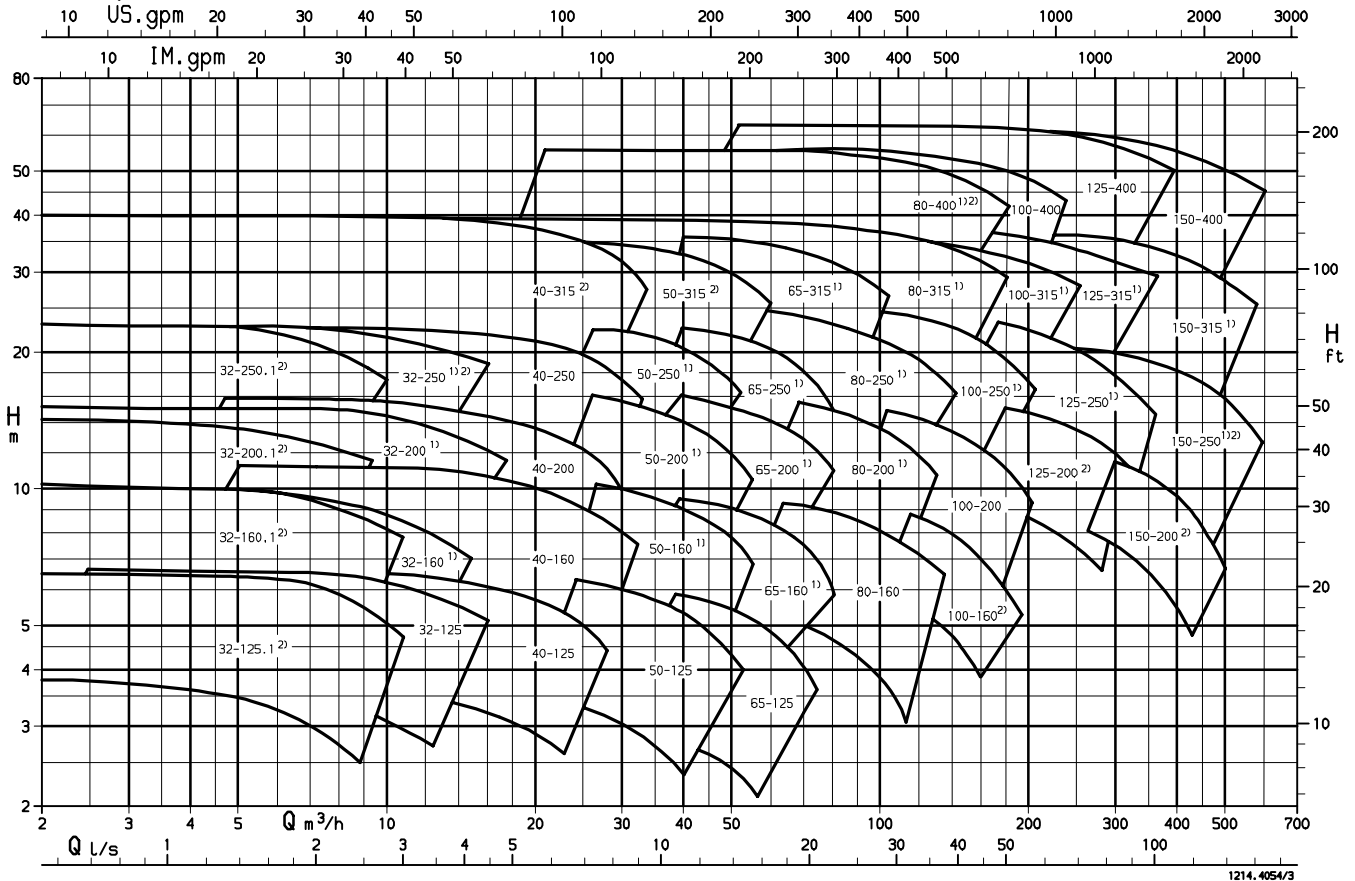

1) Lieferbar auch in: Chrom-Nickel-Molybdän-Stahlguß
Also available in: Cast chrome nickel molybdenum steel
Egalement livrable en: Acier coulé au chrome-nickel-molybdène

2) Ergänzungsgrößen in EN 733 nicht enthalten
Supplementary sizes not included in EN 733
Les tailles complémentaires ne sont pas couvertes par EN 733

Materials

Description	Etanorm GPV-D/GPV-W	Etanorm CPV-D/CPV-W
Volute casing	Grey cast iron JL1040 ²⁾	Cast chrome nickel molybdenum steel 1.4408
Discharge cover	Grey cast iron JL1040 ²⁾	Cast chrome nickel molybdenum steel 1.4408
Impeller	Grey cast iron JL1040 ²⁾ or Cast chrome nickel molybdenum steel 1.4408	Cast chrome nickel molybdenum steel 1.4408
Casing wear rings	Grey cast iron GG	Cast chrome nickel molybdenum steel 1.4408
Shaft	Tempering steel C45 or Chrome nickel molybdenum steel 1.4462	Cast chrome nickel molybdenum steel 1.4462
Bearing lantern ⁴⁾	Grey cast iron JL1040 ²⁾	Grey cast iron JL1040 ²⁾
Motor stool ³⁾	Grey cast iron JL1040 ²⁾	Grey cast iron JL1040 ²⁾
Cover plate with riser ¹⁾	General-purpose structural steel St	Chrome nickel molybdenum steel 1.4404/1.4571
Support column	General-purpose structural steel St	Chrome nickel molybdenum steel 1.4404/1.4571
Plain bearing ³⁾	SiC/SiC	SiC/SiC

1) available as accessory

2) to EN 1561 = GJL-250

3) Design W only

4) Design D only

Availability of pump sizes in the individual material variants

Pump sizes	Etanorm GPV-D/GPV-W	Etanorm CPV-D/CPV-W
32-125.1	X	X
32-160.1	X	X
32-200.1	X	X
32-250.1	X	X
32-125	X	X
32-160	X	X
32-200	X	X
32-250	X	X
40-125	X	X
40-160	X	X
40-200	X	X
40-250	X	X
40-315	X	X
50-125	X	X
50-160	X	X
50-200	X	X
50-250	X	X
50-315	X	X
65-125	X	X
65-160	X	X
65-200	X	X
65-250	X	X
65-315	X	X
80-160	X	X
80-200	X	X
80-250	X	X
80-315	X	X
80-400	X	X
100-160	X	X
100-200	X	X
100-250	X	X
100-315	X	X
100-400	X	X
125-200	X	X
125-250	X	X
125-315	X	X
125-400	X	X
150-200	X	X
150-250	X	X
150-315	X	X
150-400	X	X

Benefits at a glance

Etanorm GPV-D/CPV-D

Service-friendly, robust KSB - IEC three-phase motor V1/V15

Sturdy **deep-groove ball bearings**, permanently grease-lubricated

Cover plate is used as tank cover and for mounting the pump (available as accessory with riser)

Cantilever design
no additional bearing in the fluid

Impeller with optimum hydraulics and excellent efficiencies

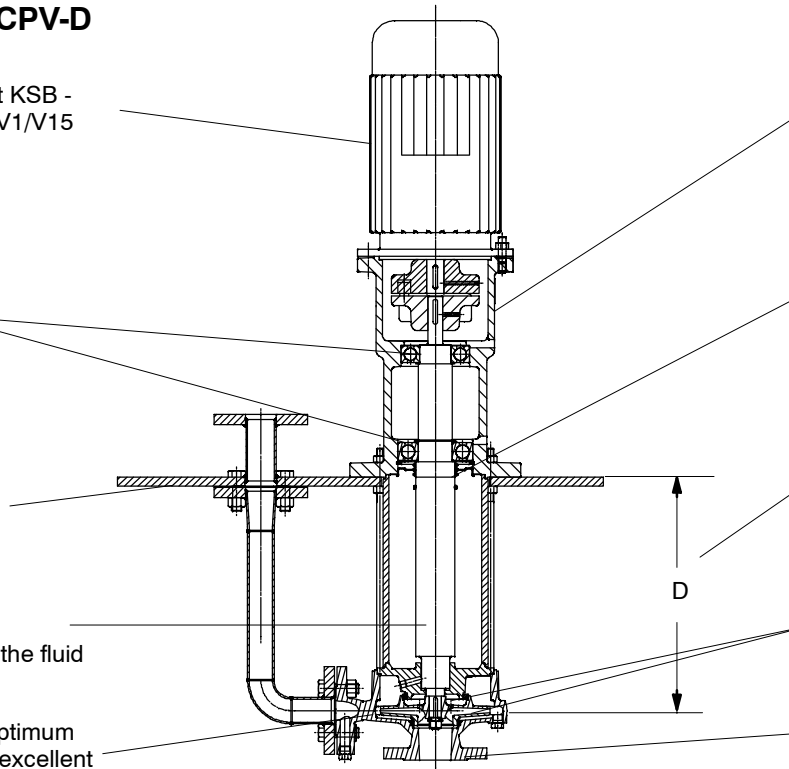

Little space required thanks to **vertical design**

V-ring and/or shaft seal ring prevent pumped fluid from entering the deep-groove ball bearing

Variable **immersion depth**

Service-friendly **casing wear rings**, no wear on the casing/impeller

Casing, impeller made of grey cast iron or cast CrNiMo steel

Etanorm GPV-W/CPV-W

Service-friendly, robust KSB - IEC three-phase motor V1/V15

No rolling element bearing above the cover plate, therefore less sensitive to short flooding of the cover plate

Cover plate is used as tank cover and for mounting the pump (available as accessory with riser)

SiC/SiC product-lubricated **plain bearing**, wear-resistant

Impeller with optimum hydraulics and excellent efficiencies

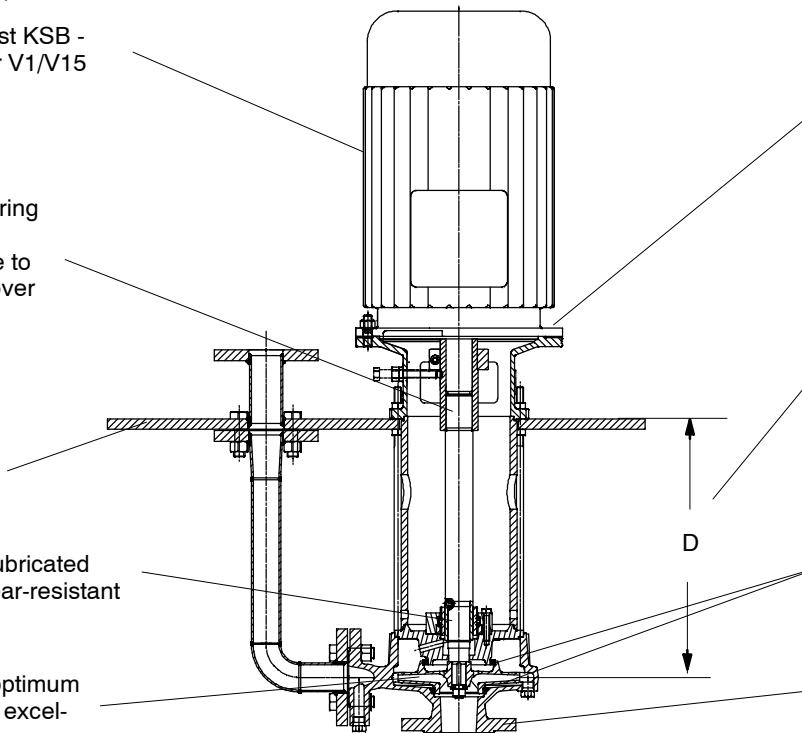

Little space required thanks to **vertical design**

Variable **immersion depth** up to D = 2000 m

Service-friendly **casing wear rings**, no wear on the casing/impeller

Casing, impeller made of grey cast iron or cast CrNiMo steel

Pressure and temperature limits

Fluid temperature t up to:

- +70 °C (design D) or
- +95 °C (design W only)

Pump discharge pressure pd up to 10 bar
 Test pressure up to 13.5 bar

Table of fluids

Fluid/Application	Material Casing / Impeller		Bearing		Additional information			
	Grey cast iron/ grey cast iron (GPV)	CrNiMo cast steel CrNiMo cast steel (CPV)	Design W (plain bearing)	Design D (cantilever)	Spec. concentration (% b.w.)	Operating temperature (°C)	Density (g/cm ³)	pH value
Water								
Cooling water ¹⁾ (without antifreeze agent)	X		X	X				
Cooling water pH value ≥ 7 (with antifreeze agent)	X		X	X				
Dam water ^{1) 3)}	X		X	X				
Partly desalinated water ²⁾	X		X	X				
Pure water ⁴⁾	X		X	X				
Raw water ¹⁾	X		X	X				
Swimming pool water, river water ¹⁾	X		X	X				
Slightly contaminated water ¹⁾	X		X	X				
Pre-treatment for surface treatment applications								
Fully desalinated water, free from solids		X	X	X		...60	1	approx. 7
Silicat-free, alkaline degreasing or cleaning agents	X	X	X	X	0.3-5	...80	1.1	8.5-13
Activation	X	X	X	X	0.3-5	...40	1.1	7.5-10.5
Zinc phosphating agent (bath)	X	X		X	approx. 5	...65	1.05	2-5
Iron phosphating agent (alkaline phosphating agent)	X			X	approx. 5	...70	1.05	4-6
Passivation		X	X	X	1...	...50	1	3-6
Soda lye	X		X	X	15-20	...20	1.18	14
Painting with surface treatment technologies								
Conventional solvent-based paints	X		X	X	...10-40		approx. 1.5	7
Cataphoresis	X	X		X	10-21	...25-35	1.05-1.1	6.0-6.7
Anaphoresis	X	X		X	10-15	...25-35	1.05-1.1	7.7
Ultrafiltrate = permeate, pure filtrate, solids content < 3 %	X	X	X	X		...20-30	1	5.5-6
Recirculated fluid, solids content < 3 %	X	X	X	X		...20-30	1.1	6
Paint water with paint residues from metal, plastic or wood paints	X		X	X		...20-30	1-1.05	approx. 7
Anolyte (dialyte) with acetic acid or formic acid, free from solids		X	X	X		...20-30	1	2.5-3.0
Accelerator (for compound preparation)		X	X	X			1.05-1.1	

1) General criteria for results of water analysis: pH value ≥ 7; chloride content (Cl) ≤ 250 mg/kg.
 Chlorine (Cl₂) ≤ 0.6 mg/kg.

2) Treatment to VdTUV 1466, in addition: O₂ ≤ 0.02 mg/l

3) If fluid contains solids, please contact KSB

4) No ultra-pure water! Conductivity at 25 °C: ≤ 800 μS/cm, neutral with regard to chemical corrosion

Combination of pumps and motors/currents

Pump size	≈ 1450 rpm		≈ 2900 rpm		Motor size
	kW	400V ≈ A	kW	400V ≈ A	
32-125.1	2.2	4.7	3.0	6.1	100L
32-160.1	2.2	4.7	3.0	6.1	100L
32-160.1			4.0	7.8	112M
32-200.1	2.2	4.7	3.0	6.1	100L
32-200.1			4.0	7.8	112M
32-200.1			5.5	10.4	132S
32-200.1			7.5	13.8	132S
32-250.1	2.2	4.7			100L
32-250.1			5.5	10.4	132S
32-250.1			7.5	13.8	132S
32-250.1			11.0	20.0	160M
32-250.1			15.0	26.5	160M
32-125	2.2	4.7	3.0	6.1	100L
32-160	2.2	4.7	3.0	6.1	100L
32-160			4.0	7.8	112M
32-200	2.2	4.7			100L
32-200			4.0	7.8	112M
32-200			5.5	10.4	132S
32-200			7.5	13.8	132S
32-200			11.0	20.0	160M
32-250	2.2	4.7			100L
32-250			7.5	13.8	132S
32-250			11.0	20.0	160M
32-250			15.0	26.5	160M
40-125	2.2	4.7	3.0	6.1	100L
40-125			4.0	7.8	112M
40-160	2.2	4.7	3.0	6.1	100L
40-160			4.0	7.8	112M
40-160			5.5	10.4	132S
40-160			7.5	13.8	132S
40-200	2.2	4.7			100L
40-200			5.5	10.4	132S
40-200			7.5	13.8	132S
40-200			11.0	20.0	160M
40-200			15.0	26.5	160M
40-200			18.5	32.0	160L
40-200			22.0	39.5	180M
40-250	2.2	4.7			100L
40-250	3.0	6.4			100L
40-250			11.0	20.0	160M
40-250			15.0	26.5	160M
40-250			18.5	32.0	160L
40-250			22.0	39.5	180M
40-250			30.0	53.0	200L
40-315	2.2	4.7			100L
40-315	3.0	6.4			100L
40-315	4.0	8.2			112M
40-315	5.5	11.4			132S
50-125	2.2	4.7	3.0	6.1	100L
50-125			4.0	7.8	112M
50-125			5.5	10.4	132S
50-125			7.5	13.8	132S
50-160	2.2	4.7			100L
50-160			5.5	10.4	132S
50-160			7.5	13.8	132S
50-160			11.0	20.0	160M

Pump size	≈ 1450 rpm		≈ 2900 rpm		Motor-size
	kW	400V ≈ A	kW	400V ≈ A	
50-200	2.2	4.7			100L
50-200	3.0	6.4			100L
50-200			11.0	20.0	160M
50-200			15.0	26.5	160M
50-200			18.5	32.0	160L
50-200			22.0	39.5	180M
50-250	2.2	4.7			100L
50-250	3.0	6.4			100L
50-250	4.0	8.2			112M
50-250			15.0	26.5	160M
50-250			18.5	32.0	160L
50-250			22.0	39.5	180M
50-250			30.0	53.0	200L
50-250			37.0	65.0	200L
50-315	3.0	6.4			100L
50-315	4.0	8.2			112M
50-315	5.5	11.4			132S
50-315	7.5	15.2			132M
65-125	2.2	4.7			100L
65-125			4.0	7.8	112M
65-125			5.5	10.4	132S
65-125			7.5	13.8	132S
65-125			11.0	20.0	160M
65-160	2.2	4.7			100L
65-160			7.5	13.8	132S
65-160			11.0	20.0	160M
65-160			15.0	26.5	160M
65-200	2.2	4.7			100L
65-200	3.0	6.4			100L
65-200	4.0	8.2			112M
65-200			15.0	26.5	160M
65-200			18.5	32.0	160L
65-200			22.0	39.5	180M
65-200			30.0	53.0	200L
65-250	3.0	6.4			100L
65-250	4.0	8.2			112M
65-250	5.5	11.4			132S
65-250			22.0	39.5	180M
65-250			30.0	53.0	200L
65-250			37.0	65.0	200L
65-250			45.0	78.0	225M
65-315	5.5	11.4			132S
65-315	7.5	15.2			132M
65-315	11.0	21.5			160M
80-160	2.2	4.7			100L
80-160	3.0	6.4			100L
80-160			15.0	26.5	160M
80-160			18.5	32.0	160L
80-160			22.0	39.5	180M
80-160			30.0	53.0	200L

Pump size	≈ 1450 rpm		≈ 2900 rpm		Motor size
	kW	400V ≈ A	kW	400V ≈ A	
80-200	2.2	4.7			100L
80-200	3.0	6.4			100L
80-200	4.0	8.2			112M
80-200	5.5	11.4			132S
80-200			18.5	32.0	160L
80-200			22.0	39.5	180M
80-200			30.0	53.0	200L
80-200			37.0	65.0	200L
80-200			45.0	78.0	225M
80-250	4.0	8.2			112M
80-250	5.5	11.4			132S
80-250	7.5	15.2			132M
80-250	11.0	21.5			160M
80-250			30.0	53.0	200L
80-250			37.0	65.0	200L
80-250			45.0	78.0	225M
80-250			55.0	96.0	250M
80-250			75.0	130.0	280S
80-315	7.5	15.2			132M
80-315	11.0	21.5			160M
80-315	15.0	28.5			160L
80-315	18.5	35.5			180M
80-400	11.0	21.5			160M
80-400	15.0	28.5			160L
80-400	18.5	35.5			180M
80-400	22.0	41.5			180L
80-400	30.0	55			200L
100-160	3.0	6.4			100L
100-160	4.0	8.2			112M
100-160			22.0	39.5	180M
100-160			30.0	53.0	200L
100-160			37.0	65.0	200L
100-200	4.0	8.2			112M
100-200	5.5	11.4			132S
100-200	7.5	15.2			132M
100-200			30.0	53.0	200L
100-200			37.0	65.0	200L
100-200			45.0	78.0	225M
100-200			55.0	96.0	250M
100-200			75.0	130.0	280S
100-250	7.5	15.2			132M
100-250	11.0	21.5			160M
100-250	15.0	28.5			160L
100-250			55.0	96.0	250M
100-250			75.0	130.0	280S
100-250			90.0	154.0	280M
100-315	15.0	28.5			160L
100-315	18.5	35.5			180M
100-315	22.0	41.5			180L
100-315	30.0	55			200L
100-400	22.0	41.5			180L
100-400	30.0	55			200L
100-400	37.0	66			225S

Pump size	≈ 1450 rpm		≈ 2900 rpm		Motor size
	kW	400V ≈ A	kW	400V ≈ A	
125-200	7.5	15.2			132M
125-200	11.0	21.5			160M
125-200	15.0	28.5			160L
125-200			55.0	96.0	250M
125-200			75.0	130.0	280S
125-200			90.0	154.0	280M
125-250	11.0	21.5			160M
125-250	15.0	28.5			160L
125-250	18.5	35.5			180M
125-315	18.5	35.5			180M
125-315	22.0	41.5			180L
125-315	30.0	55.0			200L
125-315	37.0	66.0			225S
125-400	30.0	55.0			200L
125-400	37.0	66.0			225S
125-400	45.0	80.0			225M
125-400	55.0	100.0			250M
125-400	75.0	136.0			280S
150-200	11.0	21.5			160M
150-200	15.0	28.5			160L
150-250	15.0	28.5			160L
150-250	18.5	35.5			180M
150-250	22.0	41.5			180L
150-250	30.0	55.0			200L
150-315	22.0	41.5			180L
150-315	30.0	55.0			200L
150-315	37.0	66.0			225S
150-315	45.0	80.0			225M
150-400	37.0	66.0			225S
150-400	45.0	80.0			225M
150-400	55.0	100.0			250M
150-400	75.0	136.0			280S
150-400	90.0	160.0			280M

GPV-D/CPV-D
GPV-W/CPV-W

Pump size	SU 1)	DN ₁	DN ₂	DN ₃	a	b	b1	d1	e1	h3	k	l2	l3	l4	l5	l6	m	n	n1	o
32-125.1 2)	25	50	32	40	140	110	550	173	80	112	205	280	270	155	455	100	100	6	780	190
32-160.1 2)	25	50	32	40	160	120	550	173	80	132	205	280	270	155	470	115	100	6	780	240
32-200.1 2)	25	50	32	40	180	132	550	173	80	160	205	280	270	155	483	128	100	6	780	240
32-250.1 2)	25	50	32	40	225	171	550	173	100	180	205	280	270	155	523	168	125	6	780	320
32-125 2)	25	50	32	40	140	107	550	173	80	112	205	280	270	155	451	96	100	6	780	190
32-160 2)	25	50	32	40	160	120	550	173	80	132	205	280	270	155	470	115	100	6	780	240
32-200 2)	25	50	32	40	180	136	550	173	80	160	205	280	270	155	487	132	100	6	780	240
32-250 2)	25	50	32	40	225	171	550	173	100	180	205	280	270	155	523	168	125	6	780	320
40-125 2)	25	65	40	50	140	115	550	173	80	112	205	270	270	157	458	105	100	6	780	210
40-160 2)	25	65	40	50	160	132	550	173	80	132	205	290	270	137	493	120	100	6	780	240
40-200 2)	25	65	40	50	180	152	550	173	100	160	205	310	270	117	535	142	100	6	780	265
40-250 2)	25	65	40	50	225	178	550	173	100	180	205	295	270	132	546	168	125	6	780	320
40-315 2)	35	65	40	50	250	203	550	225	125	225	255	320	270	107	599	196	125	8	780	345
50-125 2)	25	65	50	65	160	130	550	173	100	132	205	310	270	107	516	113	100	6	780	240
50-160 2)	25	65	50	65	180	148	550	173	100	160	205	330	270	87	558	135	100	6	780	265
50-200 2)	25	65	50	65	200	165	550	173	100	160	205	290	270	127	534	151	100	6	780	265
50-250 2)	25	65	50	65	225	184	550	173	100	180	205	315	270	102	587	179	125	6	780	320
50-315 2)	35	65	50	65	280	218	550	225	125	225	255	370	270	47	671	208	125	8	780	345
65-125 2)	25	80	65	80	180	148	550	173	100	160	205	350	270	60	580	130	125	6	780	280
65-160 2)	25	80	65	80	200	159	550	173	100	160	205	370	270	40	611	141	125	6	780	280
65-200 2)	25	80	65	80	225	177	550	173	100	180	205	335	270	75	597	162	125	6	780	320
65-250 2)	35	80	65	80	250	200	550	225	100	200	255	360	270	50	646	186	160	8	780	360
65-315 2)	35	80	65	80	280	229	550	225	125	225	255	390	270	49	676	215	160	8	780	400
80-160 2)	25	100	80	100	225	175	550	173	125	180	205	355	270	145	620	155	125	6	880	320
80-200 2)	35	100	80	100	250	189	550	225	125	180	255	380	270	120	660	170	125	8	880	345
80-250 2)	35	100	80	100	280	210	550	225	125	200	255	410	270	90	715	195	160	8	880	400
80-315 2)	35	100	80	100	315	244	550	225	125	250	255	445	270	55	785	230	160	8	880	400
80-400 2) 3)	55	100	80	100	355	275	700	225	125	280	255	485	355	200	860	265	160	8	1150	435
100-160 2)	35	125	100	125	280	225	550	225	125	200	255	450	270	68	744	202	160	8	880	360
100-200 2)	35	125	100	125	280	213	550	225	125	200	255	450	270	68	732	190	160	8	880	360
100-250 2)	35	125	100	125	280	220	550	225	140	225	255	450	270	68	744	202	160	8	880	400
100-315 2)	35	125	100	125	315	255	550	225	140	250	255	485	260	43	817	240	160	8	880	400
100-400 2) 3)	55	125	100	125	355	280	700	225	140	280	255	525	355	145	915	265	200	8	1150	500
125-200 2)	35	150	125	150	315	244	600	225	140	250	255	520	330	157	881	218	160	8	1150	400
125-250 2)	35	150	125	150	355	276	600	225	140	250	255	560	330	117	953	250	160	8	1150	400
125-315 2) 3)	55	150	125	150	355	276	700	225	140	280	255	560	355	92	962	259	200	8	1150	500
125-400 2) 3)	55	150	125	150	400	304	700	225	140	315	255	605	355	47	1038	290	200	8	1150	500
150-200 2)	35	200	150	200	400	318	600	225	160	280	255	645	330	43	1057	280	160	8	1150	550
150-250 2)	35	200	150	200	400	303	600	225	160	280	255	645	330	43	1047	270	200	8	1150	500
150-315 2) 3)	55	200	150	200	400	310	700	225	160	280	255	645	330	43	1053	276	200	8	1150	550
150-400 2) 3)	55	200	150	200	450	325	700	225	160	315	255	690	345	43	1129	307	200	8	1210	550

1) Shaft unit

2) Casing Etanorm CPV-W/CPV-D with foot

3) Casing Etanorm GPV-W/GPV-D with foot

Recommended spare parts stock for two years' continuous operation
Etanorm GPV-D/CPV-D

Part No.	Description	Number of pumps (including stand-by pumps)						
		2	3	4	5	6 - 7	8 - 9	10 and more
		Quantity of spare parts						
210	Shaft, complete	1	1	2	2	2	3	30 %
230	Impeller (including casing wear ring 502.2)	1	1	2	2	2	3	30 %
321	Deep groove ball bearing per size	1	1	2	2	2	3	30 %
400.1	Gasket	4	6	8	8	9	12	150 %
411.1	V-ring (SU 25 and 35) ¹⁾	4	6	8	10	12	16	100 %
411.2	V-ring (SU 55) ¹⁾	2	3	4	5	6	8	100 %
412.2	O-ring (SU 55) ¹⁾	2	3	4	5	6	7	90 %
420	Shaft seal ring (SU 55) ¹⁾	2	3	4	5	6	8	100 %
502.1/.2	Casing wear ring	2	2	2	3	3	4	50 %

1) For shaft unit / pump size combinations

Pump sizes with SU ¹⁾ 25	Pump sizes with SU ¹⁾ 35	Pump sizes with SU ¹⁾ 55
32-125.1 *	40-315	80-400
32-160.1 *	50-315	100-400
32-200.1	65-250	125-315 *
32-250.1	65-315	125-400
32-125 *	80-200 *	150-315 *
32-160 *	80-250	150-400
32-200	80-315	
32-250	100-160 *	
40-125 *	100-200 *	
40-160 *	100-250	
40-200	100-315	
40-250	125-200 *	
50-125 *	125-250	
50-160 *	150-200 *	
50-200	150-250	
50-250		
65-125 *		
65-160 *		
65-200		
80-160 *		

1) SU = Shaft Unit

* Pump size with push-fit discharge cover 163; the other discharge covers are bolted on.

Etanorm GPV-W/CPV-W

Part No.	Description	Number of pumps (including stand-by pumps)						
		2	3	4	5	6 - 7	8 - 9	10 and more
		Quantity of spare parts						
210/211 ¹⁾	Shaft	1	1	2	2	2	3	30 %
230	Impeller (including casing wear ring 502.2)	1	1	2	2	2	3	30 %
400.1	Gasket	4	6	8	8	9	12	150 %
502.1/.2	Casing wear ring	2	2	2	3	3	4	50 %
525.2	Spacer sleeve (CPV only)	1	1	2	2	3	4	50 %
99-11	Plain bearing set	1	1	2	2	3	4	50 %

1) 211 only for pumps with motor 110/112

